

Hifisonix

Speaker Protection Board

Andrew C. Russell

July 2021 (updated April 2023 with slide 9)

www.hifisonix.com

Important: This project is strictly for DIY/personal use only. If you wish to use this design, or aspects of this design, for commercial applications and/or resale, kindly contact me via the hifisonix website or at [bonsai\(at\)hifisonix.com](mailto:bonsai@hifisonix.com)

[Click here for Double sided, silk screened PCB's for the speaker Protection Board](#)

This project uses all through hole components

Specifications – Hifisonix Speaker Protection board

Protection IC: [Unisonic UPA1237](#)

Protection functions: Switch on mute, switch off mute, DC offset protection; overcurrent trip input facility

DC Offset detect speaker disengage time: < 20ms for Vdc = 50V; 100ms for Vdc = 10V; 3~5 seconds for Vdc = 2V

Current Overload disengage time: ~5ms

Usable Supply Voltage: 25 to 75V (requires resistor changes - see table on slide 6)

Options: latching/non-latching operation by means of link

Speaker Relay: TO-220 high power mosfets configured as bi-directional solid state relay

ON resistance: dependent upon mosfets used (see Table 1) but typically <20 milli-Ohms and as low as 3 milli-Ohms

Application: Can be used with single supply or split supply rail amplifiers

PCB Dimensions: 80mm x 50mm

Attention: the values shown in the circuit diagram on slide 4 are for amplifier +ve supply voltages of > 45V. For other supply voltages, see slide 6

Brief Description

This speaker protection board uses the popular UPC1237 IC to provide DC offset protection, AC power detection, DC detection and overcurrent protection (see notes later in this document), facilitating comprehensive speaker protection with just a few extra components

The original [μPC1237](#) was created by NEC Japan, but discontinued many years ago. Taiwanese semiconductor company Unisonic now supply a pin for pin replacement, the [UPC1237](#) available from numerous suppliers in the US and Europe (UK builders can get them from Cricklewood Electronics in London via their website).

There are a lot of low cost speaker protection boards based on the UPC1237 available on eBay and AliExpress. Most use cheap relays to connect the amplifier to the speakers and ***will fail*** if there is a catastrophic DC offset, as is the case if one of the output devices on the amplifier go short – [see this thread on diyAudio for example](#) – or if the amplifier output is shorted to 0V. The relays used by the complainant in this case were industrial grade Tyco 16A devices in which the contacts welded short, putting 75V DC onto the B&W 703 bass loudspeakers on one of the channels, cooking them in about 3 seconds. The repair bill was close to US\$400.

Relays are a VERY BAD solution when dealing with high voltage, high current switching, or with inductive loads.

Instead of using relays between the amplifier output and the speaker, the hifisonix speaker protection board uses power mosfets. These offer lower on resistances than relays, easily switch 10x the currents a good quality relay can, suffer no contact degradation over time, handle inductive loads and switch DC just as well as AC.

The standard UPC1237 device will work to 60V. On the hifisonix board, a simple zener voltage limiter extends the maximum operating voltage allowing use with high power amplifiers with supply voltages of up to +-75V (using suitable mosfets of course – see table later in this document)

Hifisonix Speaker Protection Board Schematic

The voltages in red were measured with a +55V supply and the AC Detect input connected to the V+ input terminal U5 and the SPKR ON LED illuminated

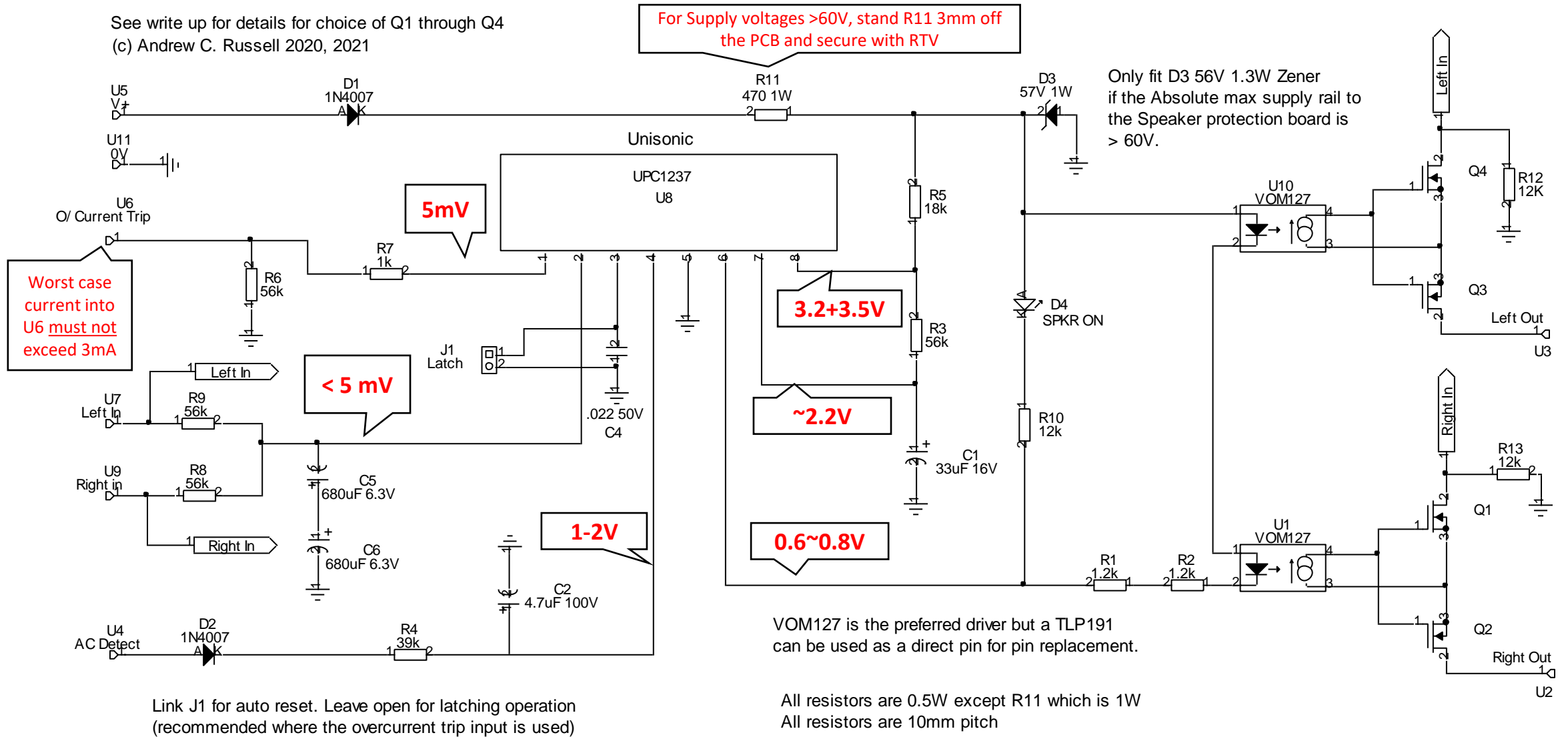

Attention: the values shown in the circuit are for amplifier +ve supply voltages of $\geq 60V$. See slide 6 for other supply voltages

Resistor values for selected supply voltages – 20V to 75V

Vs is the supply voltage at connector U5

Vs	R1	R2	R4	R5	R10
20	270	330	12k	8.2k	3900
25	330	330	15k	8.2k	4700
30	390	390	18k	10k	5600
35	560	560	22k	10k	6800
40	680	680	27k	12k	6800
45	820	820	27k	15k	8200
50	1k	1k	33k	15k	10k
55	1k	1k	33k	18k	10k
60	1.2k	1.2k	39k	18k	12k
65	1.2k	1.2k	39k	18k	12k
70	1.5k	1.5k	39k	18k	12k
75	1.5k	1.5k	39k	18k	15k

Note: Above 57V, a simple zener regulator (D3) limits the supply voltage to 57V. See the circuit diagram for details.

Table 1 – Mosfet Selection. Note: All mosfet types are TO-220.

Amplifier Absolute Max Supply Voltage	Suggested Mosfets
<= +-30V	IRLB8748PBF , IPP042N03L G , PSMN2R7-30PL,127 , IRLB8743PBF , STP200N3LL
+40V	PSMN2R1-40PL , PSMN1R9-40PL , IRF40B207 , TK3R1A04PL,S4X , IPA041N04NGXKSA1 , PSMN8R0-40PS,127 , IPP80N04S404AKSA1 , PSMN4R5-40PS,127
+50V ~ +-60V	BUK954R8-60E , PSMN2R5-60PL , PSMN3R3-60PLQ , PSMN4R2-60PL , IXTP120N075T2 , STP220N6F7
>+-60V ~ +-75V	PSMN3R5-80PS , PSMN4R4-80PS , PSMN4R3-80PS , FDP4D5N10C , TK5R3E08QM,S1X , FDP053N08B-F102 , IRF1407PBF , DMTH10H005LCT , SQP120N10-09 GE3 , PSMN3R3-80PS,127

Device Pinout

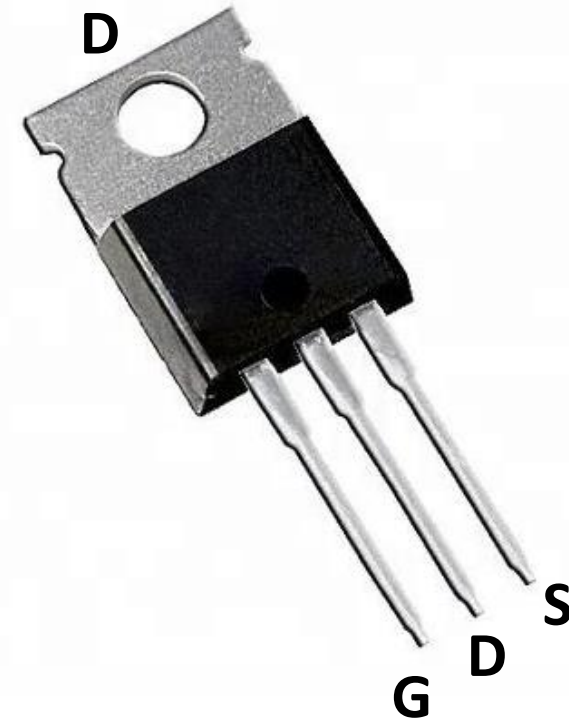

The table above is a list of indicative power mosfets that can be used with the speaker protection board. In general, logic level types with lower gate charge ('Qdg') are preferred.

How to wire in the Protection Board to your Amp

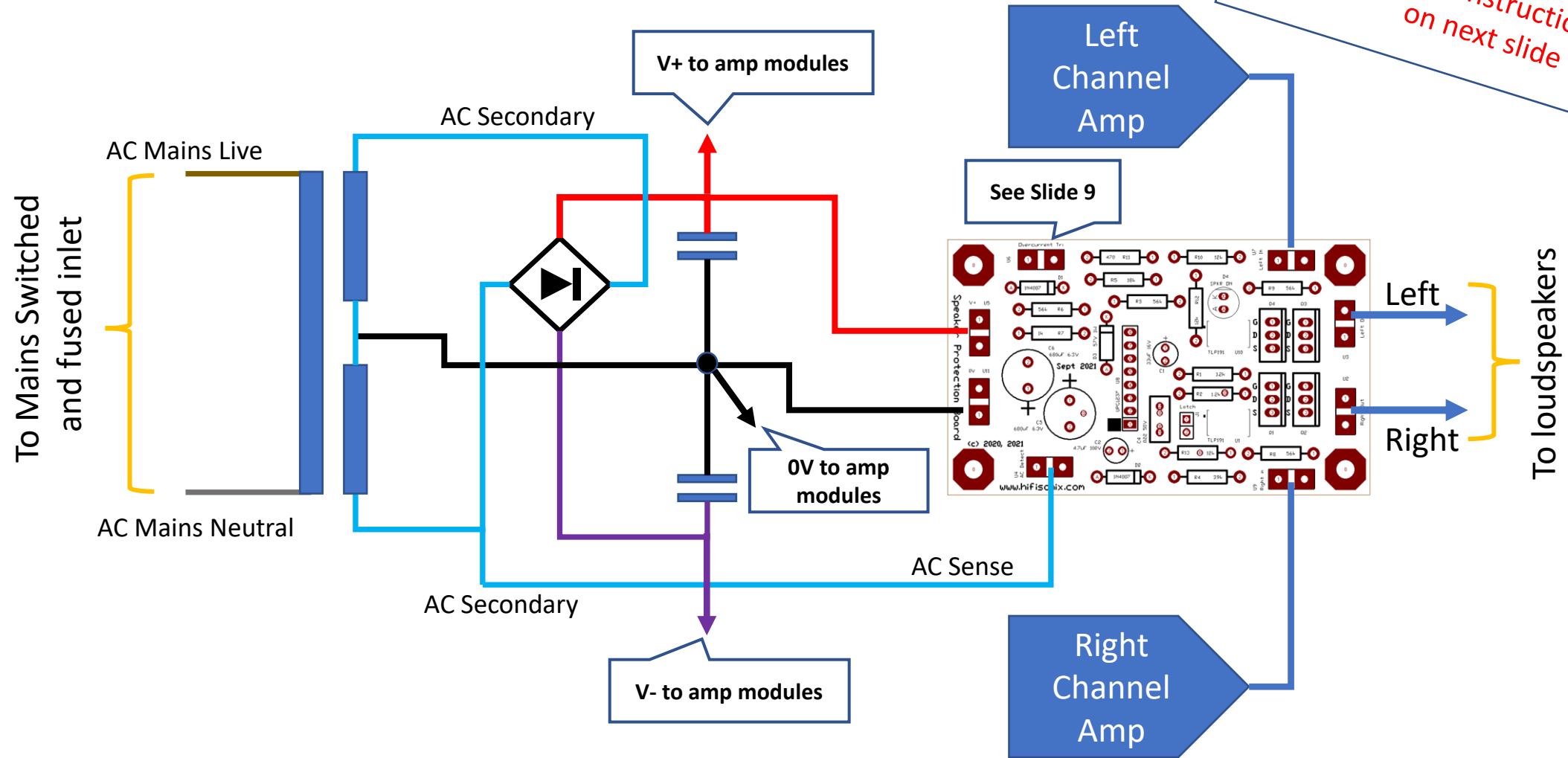

This wiring-up scheme assumes a common PSU for the two channels. For monobloc construction, see notes on next slide

How to Wire the Protection Board AC Sense with Split Separately Rectified and Smoothed Secondaries

This wiring-up scheme assumes a common PSU for the two channels. For monobloc construction, see notes on next slide

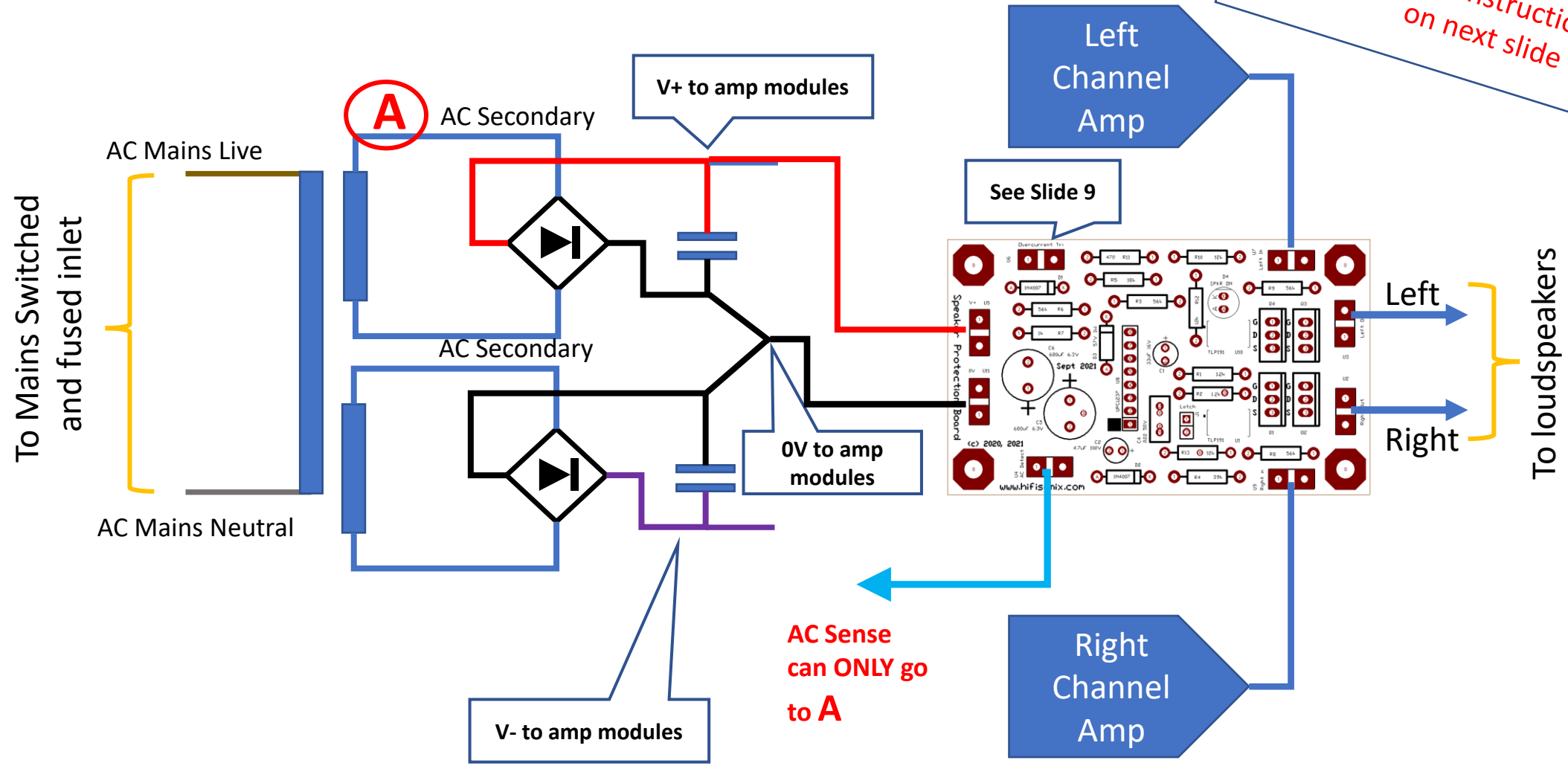

What if my amp uses separate power supplies for each channel?

- You only need one AC detect signal, so its ok to take it off just one of the secondaries. All the protector board is doing is looking to see if AC is present - it gives a long speaker switch-on delay when AC is applied but a quick one when the AC is removed. This AC detection is used to prevent speaker ON/OFF thumps when you power your amp up or down.
- If you are using separate +- supplies for each amplifier (i.e. monobloc construction) you can also just take the +- supply to the protection board off 1 amplifier power supply **provided the two amplifiers share the same 0V**. This will typically be the case if the amplifier 0 Volts are connected to the chassis for safety, or, if the input signal grounds are joined together at the input socket and the amplifier main 0V goes to the chassis via a ground lifter.
- If the two amplifier channels 0V's are not joined in any way, you will need to use a separate Speaker Protection board for each channel

Using the Current Overload Detection Input (terminal U6)

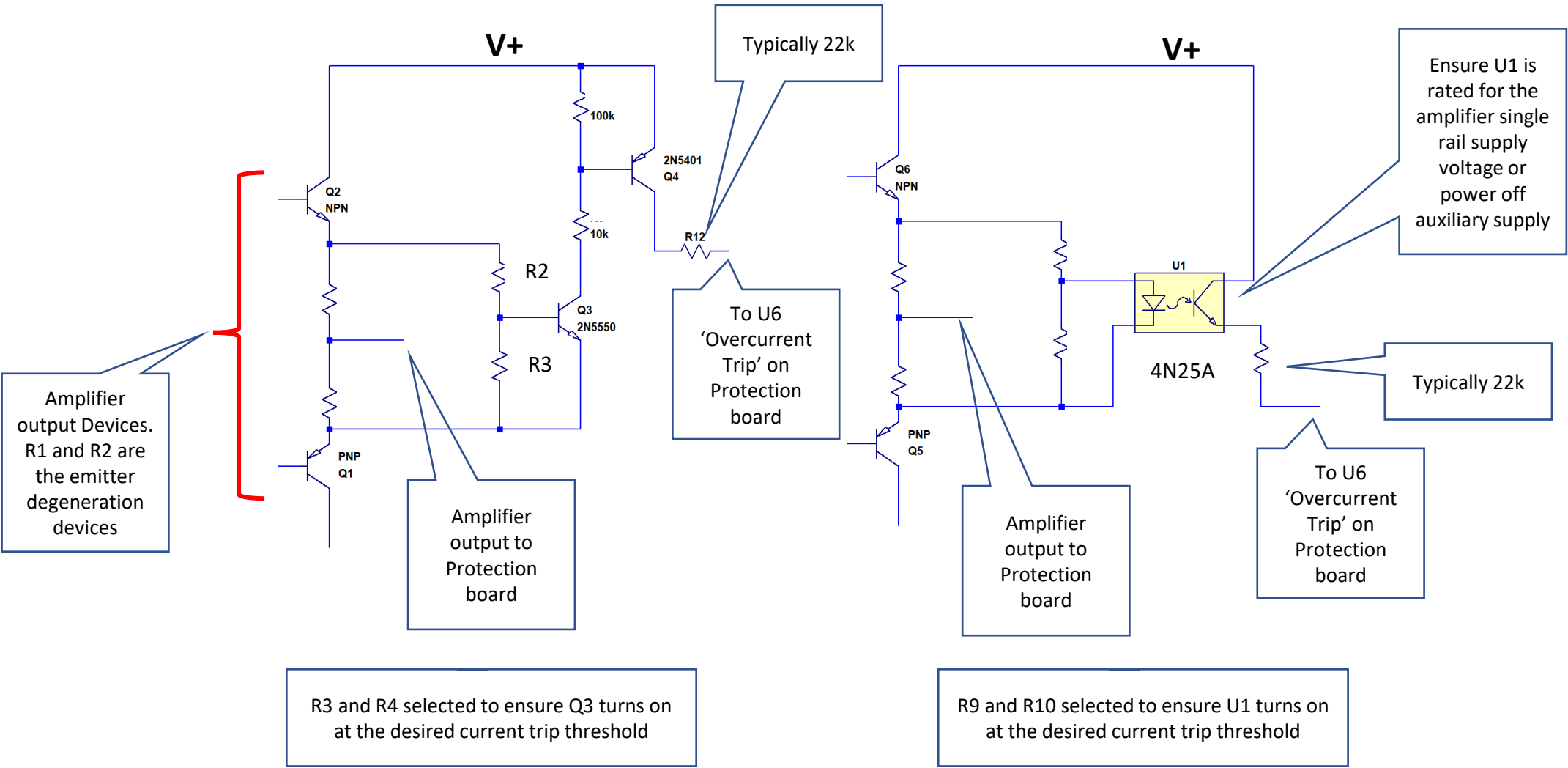

Overcurrent Protection with multiple output pairs

You can approach the current limiting in either of these two ways:-

1. Set the trip current for one pair. The total load current will then be the trip current on the sensing pair multiplied by the number of output pairs. Example: assume a 6 pair amplifier. Set the overcurrent trip for the sensing pair at 7A then the total output current of the amplifier before tripping will be 6 x 7 or 42A
2. The other method is to set the max allowable current for a given configuration, and then calculate the current trip setting resistors for the total output current. Example: assume a 6 pair amplifier where you want to set the max total output current for 30A. Each pair will then conduct 5A and the current trip resistor values selected accordingly.

I do not recommend using an output transistor pair much above 7A. If you want more output current, add more output pairs. See Robert Cordell 'Designing Audio Power Amplifiers' (2011 Edition) page 290 fig. 14.8

It is strongly recommended that the Speaker Protection Board is set to 'Latching' operation if you are using the overcurrent detect feature. To enable Latching functionality, leave J1 OPEN. If the Speaker Protection Board trips on overcurrent detect, you will have to power the amplifier completely down to reset it

Transistor overcurrent sensing circuit (simulation)

Current thru R6 into overload pin. Note R6 is in series with U6 on the board

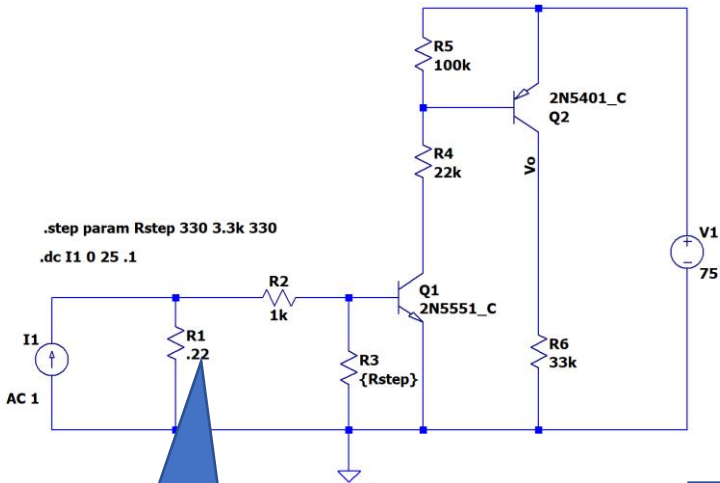

Note Rsense is 0.22 Ohms in this model

Rstep = 3.3k Ohms

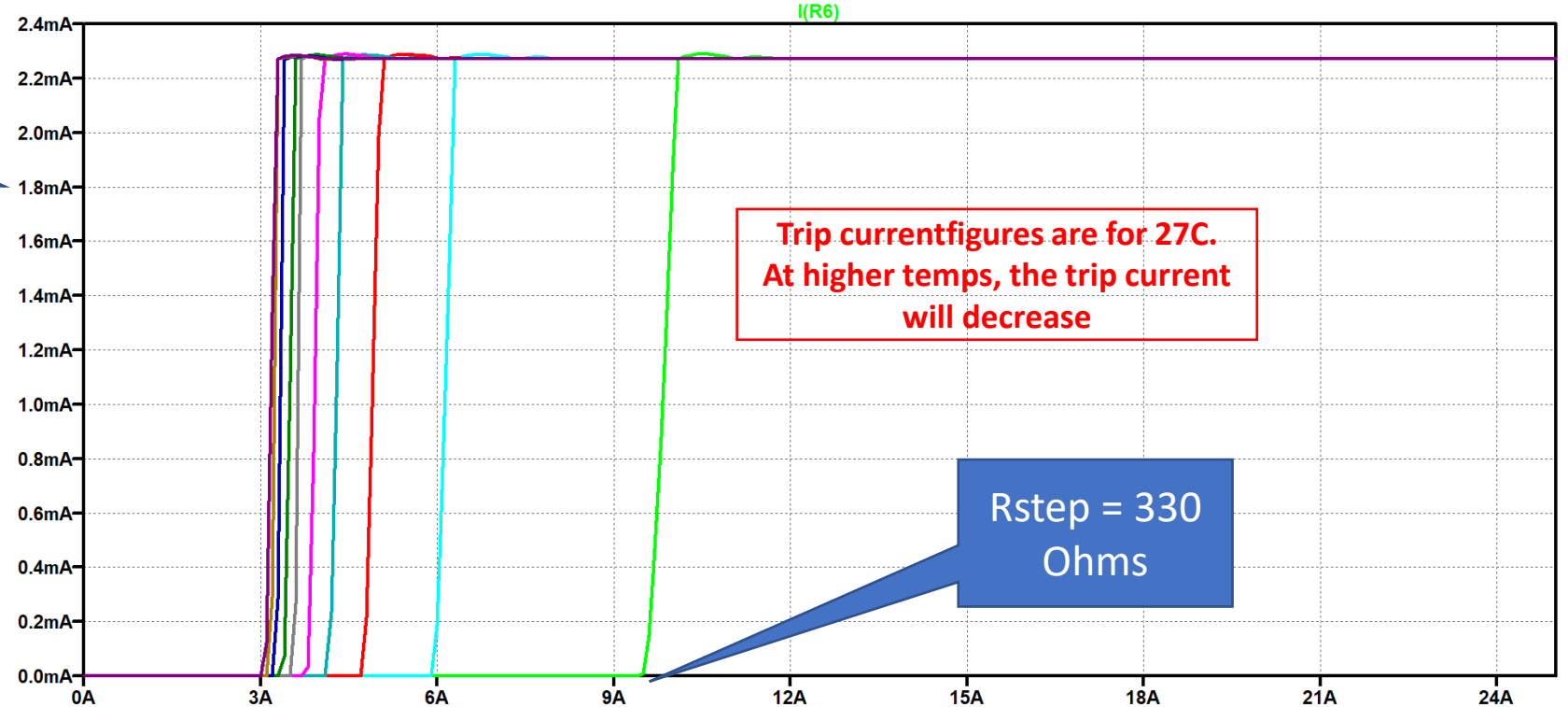

Trip current figures are for 27C. At higher temps, the trip current will decrease

Rstep = 330 Ohms

Trip current range is 3A to 9.5A for Rstep = 3.3k down to 330 Ohms

See next two slides >>

Output stage emitter degeneration resistor value

R3	0.1	0.12	0.15	0.18	0.22	0.27	0.33	0.39	0.47
180	35	29	23	19.1	15.8	12.7	10.4	8.7	7.3
220	29	24.2	19.5	16.2	13	10.8	8.8	7.5	5.9
270	24.5	20.8	16.5	13.8	11.1	9	7.4	6.4	5.2
330	20.1	17.7	14.2	11.7	9.6	7.8	6.4	5.4	4.5
390	18.6	15.5	12.6	10.4	8.5	7	5.6	4.7	4
470	16.3	13.7	11	9	7.3	6.1	5	4.3	3.5
560	14.5	12.2	9.8	8.1	5.9	5.3	4.4	3.7	3
680	12.8	10.8	8.7	7.2	5.2	4.8	3.9	3.4	2.8
820	11.5	9.6	7.8	6.5	4.7	4.3	3.5	3	2.4
1k	10.3	8.8	7	5.8	4.4	3.8	3.2	2.6	2.2
1.2k	9.2	8	5.9	5.4	4	3.4	2.9	2.6	2
1.5k	8.4	7.3	5.3	4.8	3.7	3	2.6	2.3	1.8
1.8k	8.1	6.8	5.4	4.5	3.4	2.8	2.5	2.1	1.5
2.2k	7.5	6.3	5.1	4.2	3	2.6	2.4	1.9	1.6
5.6k	6.1	5	4.2	3.3	2.7	2.2	1.8	1.7	1.2

As already mentioned, it is not recommended you use combinations in the pink coloured area which is > 7.3A per output transistor pair.

1. Select your emitter degeneration resistor value column
2. Select the peak current output you want per output pair – limit it to the white area in the table
3. Look on the left hand side column to ascertain the value of R3 (this is the lower leg of the sense transistor base voltage divider). R2 is always 1k per the previous slide.

Transistor Current Sensing Circuit Performance

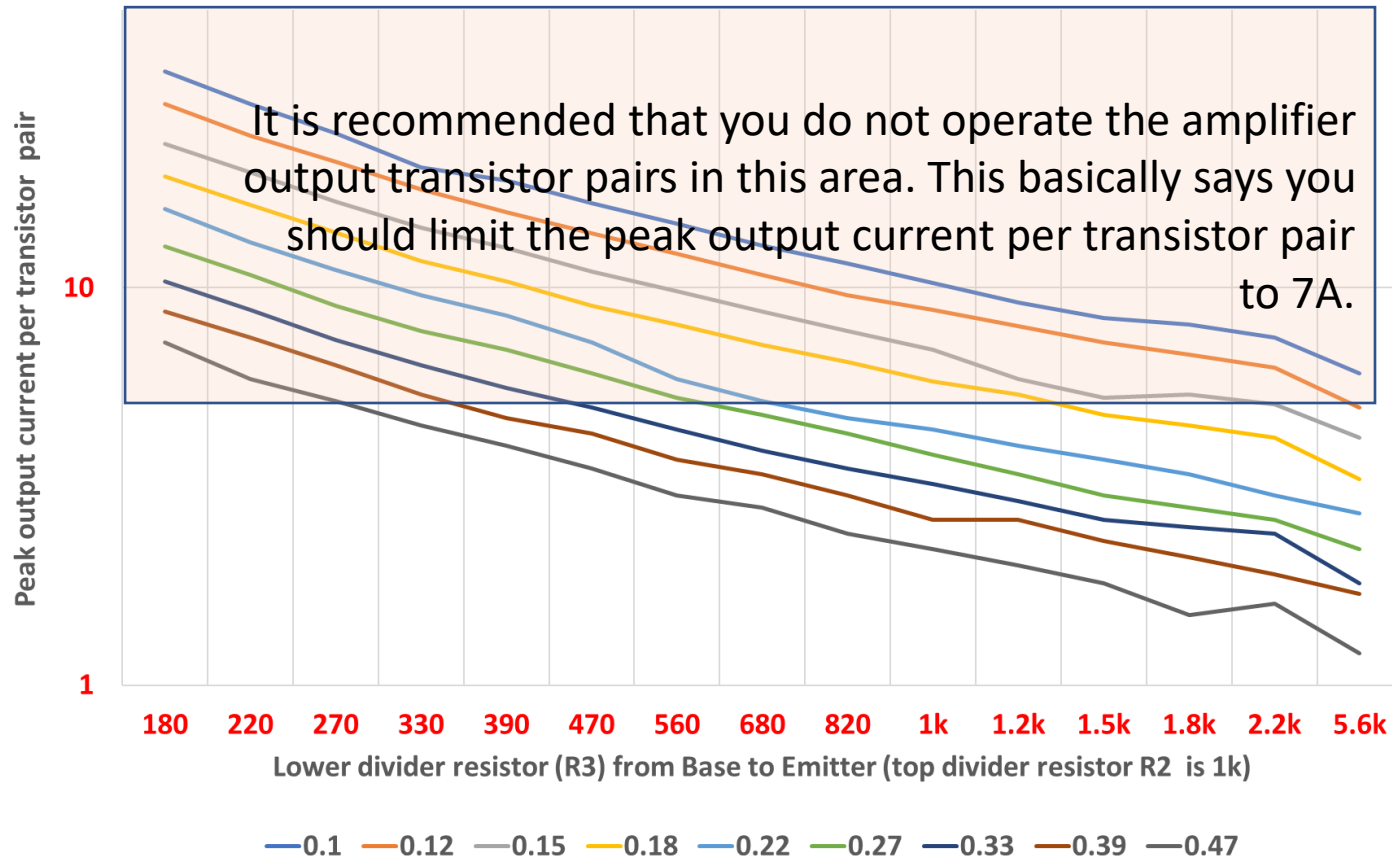

This graphic shows the performance of the transistor sensing circuit (simulation). The current limiting spread gets tighter with higher values of emitter degeneration resistor, and with higher R3 values.

Example: Say your emitter degen resistor value is 0.18 Ohms and you want to limit the output current to 6A. Locate the 0.18 curve (orange 4th from top) and see that it intersects at the 1k vertical line. Make R3 1k Ohms

The total output current of the amplifier will be the # of pairs multiplied by the current per pair.

Opto overcurrent sensing circuit (simulation)

Current thru R6 into overload pin. Note R6 is in series with U6 on the board

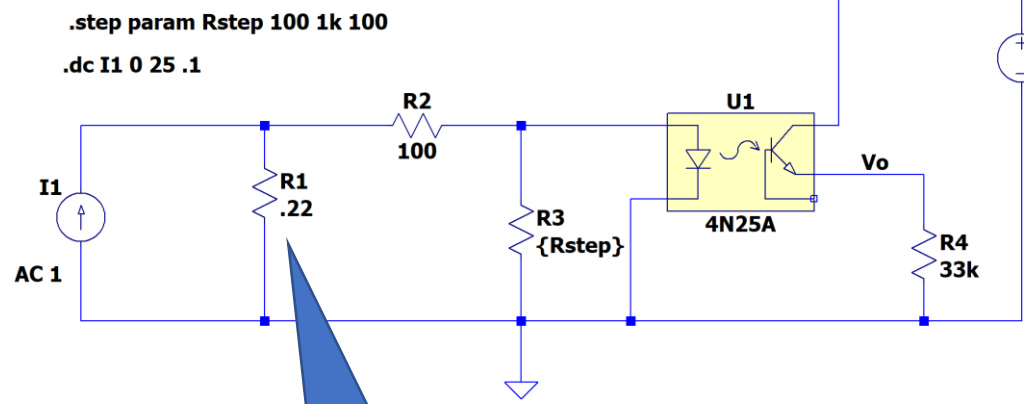

Note Rsense is 0.22 Ohms in this model

Rstep = 1k Ohms

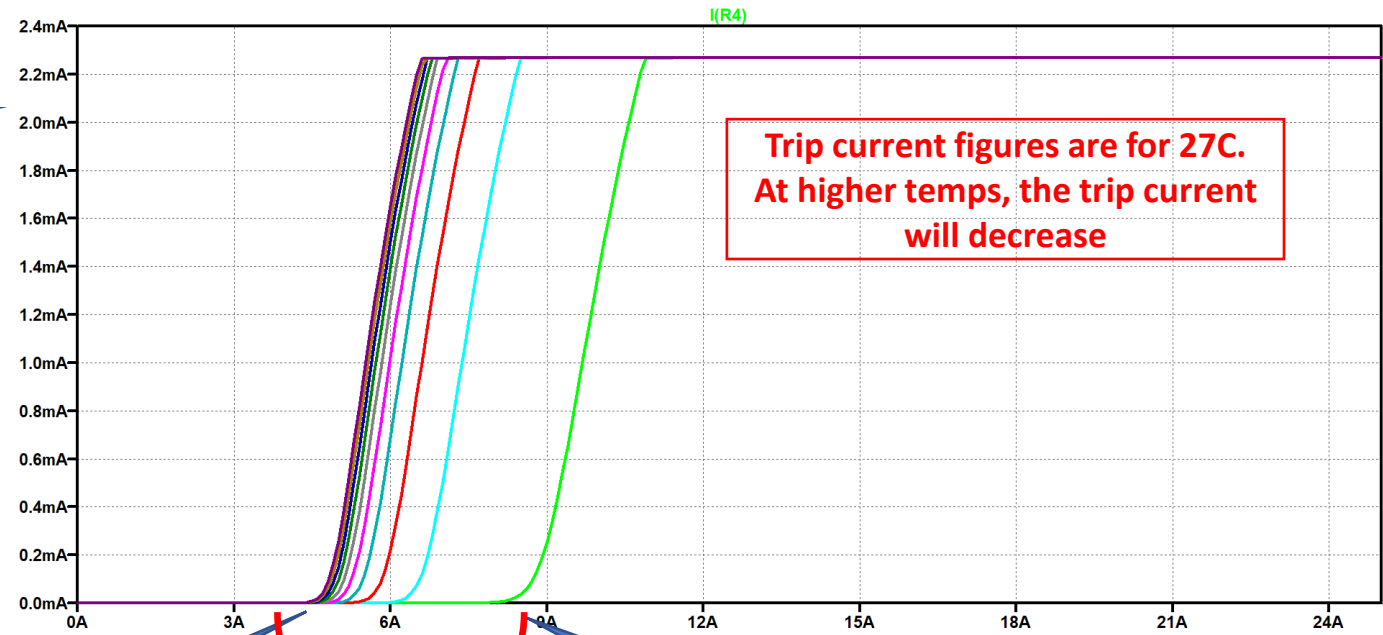

Trip current range is 4.5 to 9A for Rstep = 1k down to 100 Ohms

Rstep = 100 to 1k Ohms

Opto overcurrent sensing circuit

- It is recommended that you only use this circuit for emitter degeneration resistor values of 0.33 Ohms and higher so that sufficient voltage can be developed across the sensing resistors under fault conditions to be able to set the trip current at a reasonably low level.
- The slope of the trip activation current (ie the current coming out of the opto emitter pin) is dependent upon the current through the opto emitter diode – the lower it is, the flatter the slope and the wider the variation in trip current from unit to unit.

Opto emitter resistor selection

$$R_2 = \frac{\left[\frac{v_S}{R_{Lmin}} \times R_E \right] - v_D}{I_D}$$

- Where R_2 is the resistor in series with the opto emitter diode
- R_{Lmin} is the lowest load impedance the amplifier must drive – below this resistance, the protection circuit must kick in. A good value is 2.8 Ohms
- R_E is the emitter degeneration value – for the opto circuit, it is recommended you stay ABOVE 0.22 Ohms
- v_D emitter diode voltage for a current of 5 mA

To prevent ‘false’ tripping, R_3 should always be fitted and must be empirically selected. A good option here is to wire a 1k pot in place of R_3 and then drive the amplifier into the minimum load impedance at full power. Then adjust the pot so that the amp trips at the correct value – then remove the pot, measure the resistance and install a resistor of the same measured value into your circuit.